

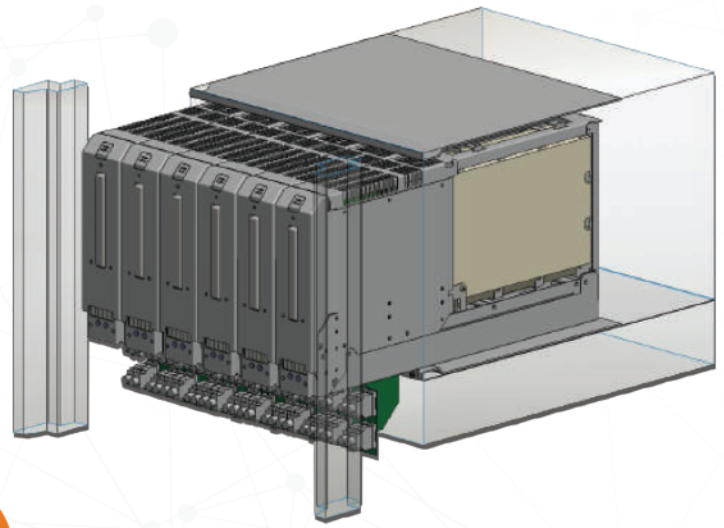

Next Generation Infinity

MICRO OVEN System



OVEN ADVANTAGES:

- Dedicated Micro OVEN per DUT board with up to 16 DUTs per oven.
- The only oven in the industry with an individual dedicated heater and temperature sensor per socket.
- Best-in-class temperature accuracy and uniformity from low to 350°C.
- Flexible wire bonding.
- Dedicated temperature micro-controller per oven.
- Digital oven temperature display per unit.
- Easy DUT board loading and unloading.
- 600 mil and 300 mil ready sockets for packages with up to 28 pins.
- Low power consumption.
- Field-proven system with installations at major semiconductor companies.
- Occupies less floor space than any other available system, with hundreds of sources per rack.
- Take a Micro OVEN system offline without disrupting other systems.
- Expandable system—add more capacity as needed.

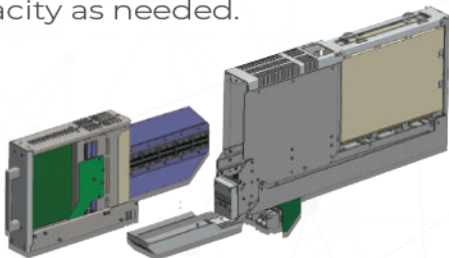

Individual Temperature Sensor per socket

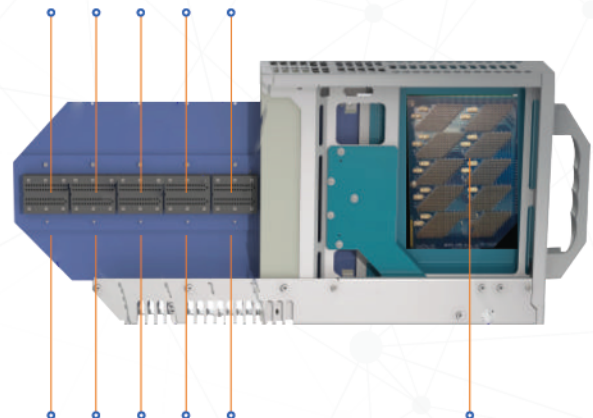

Individual local heaters per socket

In-line resistor and cap area

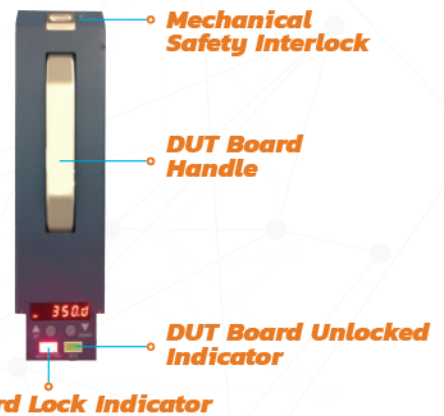

Mechanical Safety Interlock

DUT Board Handle

DUT Board Unlocked Indicator

Dut Board Lock Indicator

Consult QualiTau for detailed specifications.

TESTING THE FUTURE

SALES@QUALITAU.COM